

invoice / delivery address

Reference:

Tilaus

Tarjous

Turvaistuin



Exportprices

Release: 2019

BASIC

Details:

	IPAI-NXT WITHOUT extra cushion	IPAI-NXT WITH extra cushion
SEAT WIDTH (pelvis)	31 cm	26 cm
SEAT WIDTH (knee)	34 cm	34 cm
SEAT DEPTH	30 cm	27 cm
BACK HEIGHT	41 - 54 cm	38 - 51 cm
CROWN HEIGHT	59 - 74 cm	56 - 71 cm
HEIGHT LATERALS	20 - 33 cm	17 - 30 cm
DISTANCE LATERALS	14 - 28 cm	
angle	85° - 160°	
total height	68 - 88 cm	
total width	51 cm	
total depth	42 cm	
weight	ab 7,0 kg	
capacity	36 kg	

common information (standard):

- crash tested according to ECE-R44/04
- 5-point-harness with upholstery, height adjustable
- belt mechanics installed into the front of the seat
- solid aluminium board, including the mechanism to recline the backrest stepless
- head rest height adjustable, including belt guides
- additional upholstery (20 mm) for the back & headrest



ATTENTION: ISOFIX adapter or clamp bow necessary for children with poor trunk control or spasticity. Tilting danger!!!

IPAI-NXT red-black
(450000-ST-1)



IPAI-NXT grey-black
(450000-ST-2)



belt adjustment

central adjuster between the knees (450000-Z)



separate adjusters left and right at the height of the breast (450000-G)



accessory that makes the base board NECESSARY

Necessary for the options below!
(450000-BP)

BASE BOARD

swivel base

Gr. 1 - 3
(450200-ST)

left

right



fastener
(independent of the direction of rotation)

inside
(standard)

outside
(450220-ST)

angular adjustment (0° - 10°)
(450100-ST)



extra angular adjustment + 10°
(10° - 20°)
(450110-ST)*

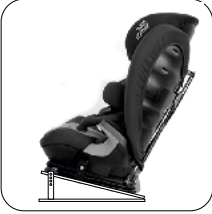

* needs standard angular adjustment (450100-ST)

ISOFIX

ISOFIX adapter
(450575-ST)



hide installation of the ISOFIX adapter
(450790-ST)

This option helps to hide the ISOFIX adapter below the car seat instead of mounting it behind. The position is now closer to the back seat - necessary for some car models VW Caddy, Touran and some Fords!!!

note: ISOFIX adapter is not included!!!

clamp bow
(450550-ST)



foot rest

(450450-ST)



swing up*
(450452-ST)

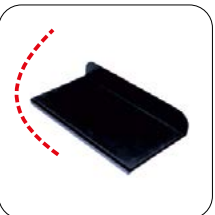

*450450-ST necessary!

outrigger*
(450453-ST)

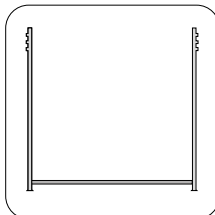

*450450-ST necessary!

foot roll

(450455-ST)

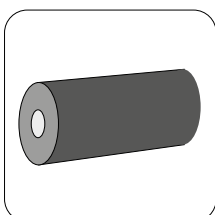

extra cushions

<input type="checkbox"/> back cushion (450700)	<input type="checkbox"/> seat cushion (450720)	<input type="checkbox"/> head upholstery, left & right (450740)	<input type="checkbox"/> head upholstery, behind (460750)	<input type="checkbox"/> upper body upholstery, pair (450710)	<input type="checkbox"/> hip upholstery, pair (450730)
reduces seat depth about 3 cm	reduces back height about 3 cm	head rest gets more tight about 5 cm	head comes 2 cm forward	reduction of back width about 6 cm	reduction of seat width about 6 cm

fittings for stabilization

<input type="checkbox"/> abduction block, removable (450400-ST)	<input type="checkbox"/> head fixation (450630-ST)	<input type="checkbox"/> security tray (450600-ST)	<input type="checkbox"/> side supports, pair, individually adjustable in height, deep and width (450800-ST)

further options

protection mat (to protect the original seats of the car) <input type="checkbox"/> (450780-ST)	belt to connect the chest straps (to improve the position of the belt in front of the breast) <input type="checkbox"/> (450640-ST)	security pad for the buckle <input type="checkbox"/> with snap fastener (450650-ST) <input type="checkbox"/> with magnetic lock (450655-ST)

notes

.....

.....

.....